

Network Protocols

IP Multicast

Recall

- Unicast
- Broadcast
- Multicast
 - Unicast sender address
 - Send to/received by specific IP address group

Unicast one-to-many

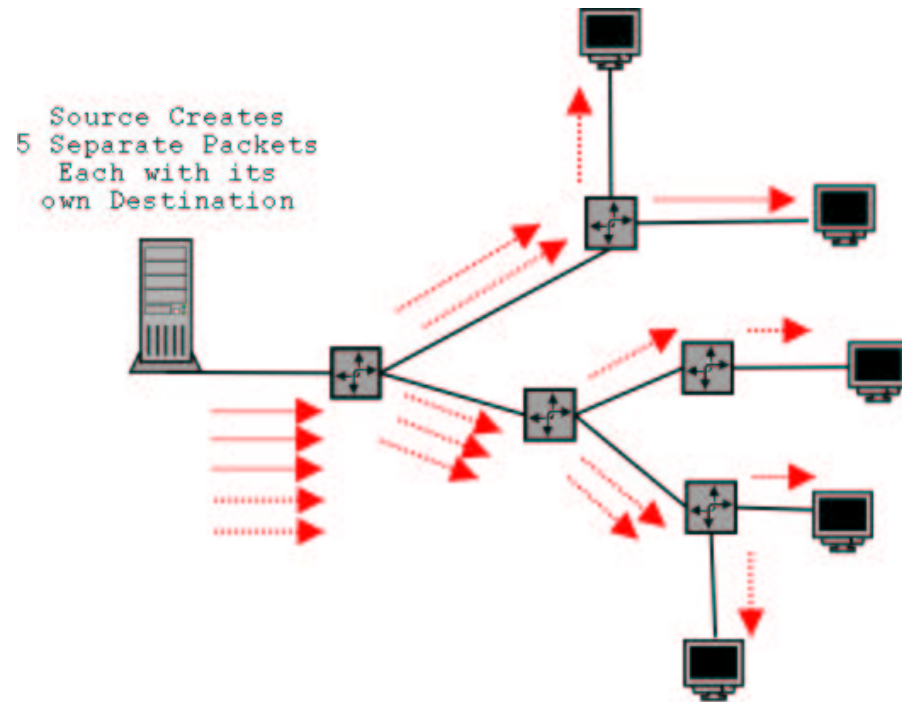

Multicast one-to-many

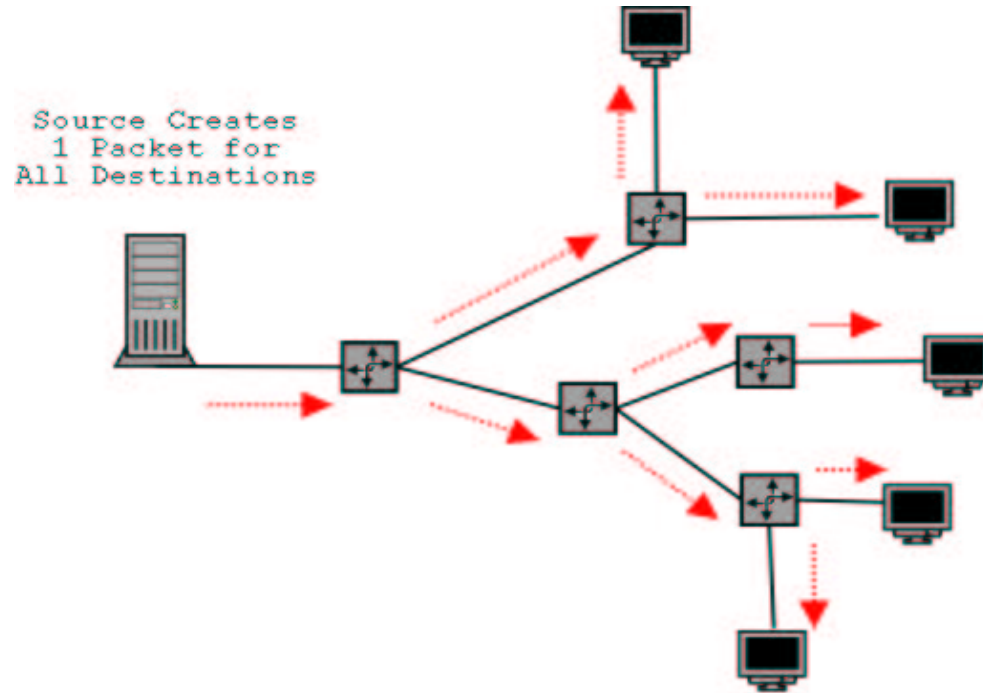

Multicast operation overview

- Class D destination address space
 - (224.0.0.0/4)
 - First bits of first octet must be 1110
- How do multicast groups become known?
- How do receivers join/leave multicast group?
- How to get multicast data to all receivers?
- How to map IP destination to MAC address?

IP multicast addressing

- Reserved/assigned addresses
 - 224.0.0.0/24 – link local
 - 239.0.0.0/8 – administratively scoped
 - Etc... see IANA multicast address assignments
- IP to Ethernet MAC mapping
 - Take IP destination low-order 23 bits
 - Put into Ethernet destination low-order 23 bits
 - Well known Ethernet OUI = 01:00:5e

Internet group multicast protocol (IGMP)

- Host/router membership signalling protocol
- Hosts use IGMP to join/leave groups
- Routers use IGMP to build forwarding state
- IGMPv1 - 1st generation host/router protocol
- IGMPv2 – hosts use explicit leave messages
- IGMPv3 – hosts selectively filter sources

IGMP packet formats

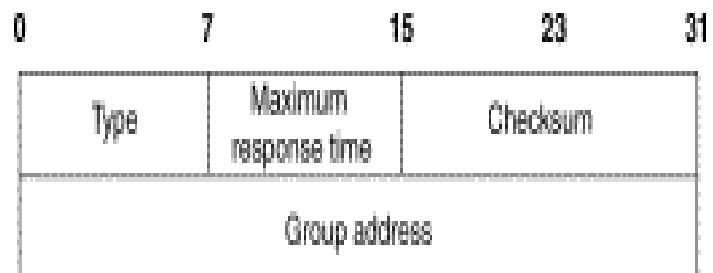
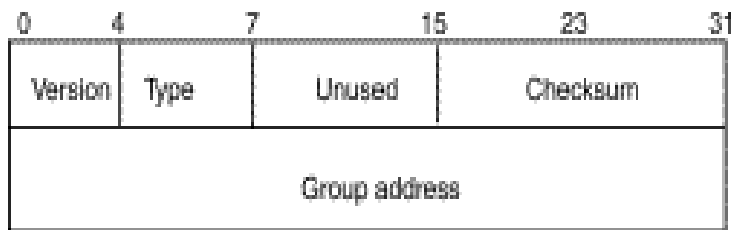

IP multicast routing

- Broadcast and prune (DVMRP, PIM-DM)
 - Reverse shortest path tree
 - Routers do reverse path forwarding (RPF) check
- Explicit join (CBT, PIM-SM)
 - Receivers send join to a rendezvous point (RP)
 - Senders send multicast data to RP, up the tree
 - RP fans out multicast data (its a meeting point)
 - Optimizations in PIM-SM short-cut the RP

Distance vector multicast routing protocol (DVMRP)

- Similar to RIP
- Infinity = 32 hops
- Flood throughout, prune back if necessary
- Graft back leafs if necessary – requires state
- 1st generation MBONE protocol – deprecated
- Scales poorly
- PIM-DM is similar – OK for dense population

Protocol independent multicast – sparse mode (PIM-SM)

- Underlying unicast forwarding info is used
- Receivers must explicitly join groups
- Everyone meets at rendezvous point (RP)
- RP is the core of a unidirectional tree
- Senders encapsulate multicast data to RP
- RP can forward, join or de-register
- Optimization allows short-cuts around RP
- Also has some scaling and RP reliance probs

PIM-SM illustrated

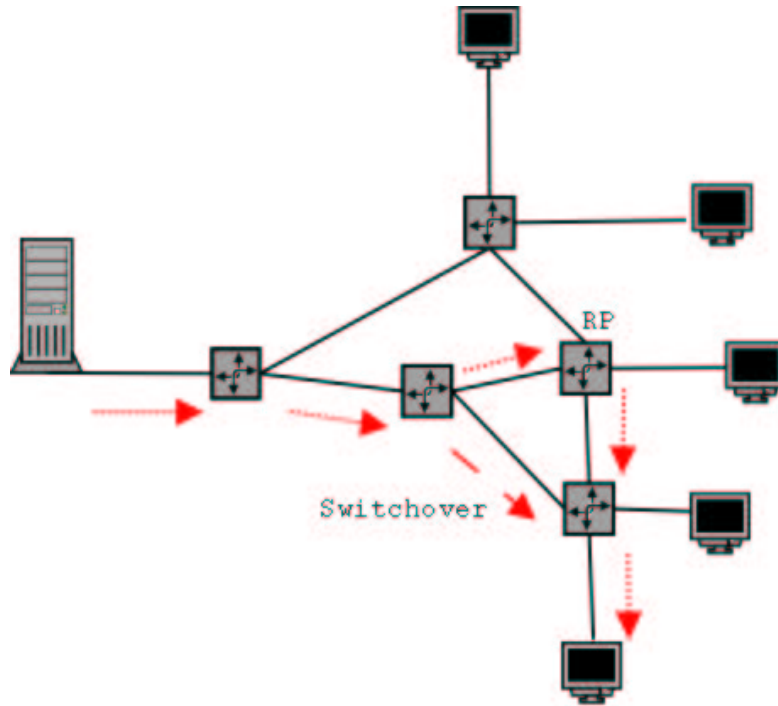

Multiprotocol BGP

- Extensions to BGP to carry other routes (e.g. Multicast)
- Can provide aggregation, routing policy, etc.
- Used between autonomous system (AS) domains
- Carries information about sources of multicast

Multicast source discovery protocol (MSDP)

- Typically an RP is deployed per AS
- RPs must know about Internet-wide sources
- MSDP sends session announcements (SAs)
- MSDP TCP sessions between RPs peers
- MSDP messages are flooded to all RPs

Internet IP multicast

- From DVMRP MBONE to today
- Some deployment – mostly Internet2
- PIM-SM/MBGP/MSDP used today
- Single source multicast (SSM) coming
- Security and denial of service attack issues
- Common tools and apps
 - IP/TV, sdr, mtrace, etc...